

Multimedia stand technical specification



.mdd

.mdd has a leading position among manufacturers of office furniture with many awards that prove quality and continuously increase demand for its products.

The realities of today's market require constant quality improvement at all levels of modern organization. This applies in particular to customer service, marketing, quality of products and also to quality of processes within the company. Partnership relations among employees and with business partners form a base of economic growth and success of the company.

Constant investments in innovative machinery park, optimization of management systems and an expansion of production halls allow to minimize the lead times for the product of the highest quality.

More than twenty years of experience in office furniture industry come with reference from a long list of companies and institutions to show their appreciation for an efficient and comprehensive service.

.mdd is highly aware of the environment.

Being located in the forest region with lake by its side, .mdd takes the nature seriously and invests constantly in a modern and energy-efficient solutions to preserve the local life. Company puts emphasis on waste segregation and recycling. .mdd has been awarded for the exceptional care and involvement in waste disposal. All materials used are environmentally friendly and enjoy a high 95 % rate of being recycled.



General informations:

Warranty:

.mdd products – 5 years.
Electrical components and fabric – 2 years.

Certificate – MFC:



Assembly:

product delivered in separate elements

Packing:

cardboard

Boards density:

12 mm – 690 – 750 kg/m³
18 mm – 650 – 690 kg/m³
28 mm – 610 – 630 kg/m³
36 mm – 610 – 630 kg/m³

Material composition *:

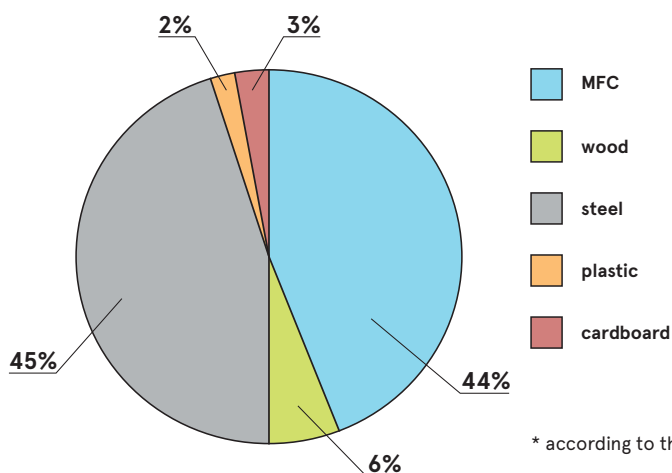

* according to the EPD document

Recyclability **

Recycling: 1% - Downcycling: 99%

Recycled content

0,8%

Co2 carbon footprint

4,73 kg

** average values for a representative of the group; values may vary for other products

Technical specification - MS01, MS02

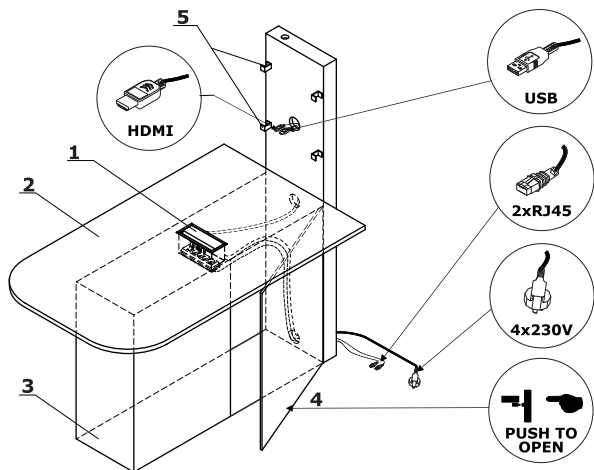

1. Mediabox M04H - 2xRJ45 (class E, cat. 6); + 1 x USB + 1 x HDMI + 4 x 230V
2. Worktop - MFC 28 mm, ABS edge
3. Base - MFC 28 mm, ABS edges
4. Front - Push-to-Open, MFC 18 mm, ABS edge
5. Handles - VESA fixing, spacing 400x400 mm, max weight of TV 20 kg

ATTENTION - SCHUCKO plugs only

Opis techniczny - MSW01

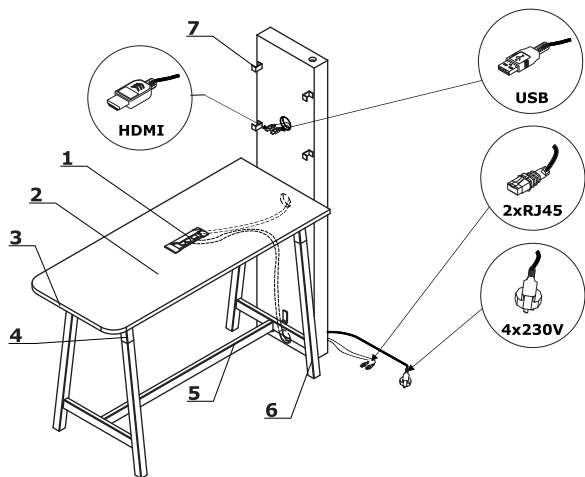

1. Mediabox M04H - 2xRJ45 (class E, cat. 6); + 1 x USB + 1 x HDMI + 4 x 230V
2. Worktop - MFC 28 mm, ABS edge
3. OPTION WITH EXTRA CHARGE - worktop edge, colour: ash natural
4. Metal element - powder coated
5. Frame - metal, profile 50 x 50 mm
6. Natural wood - ash, coated with transparent varnish, profile 40 x 40 mm
7. Handles - VESA fixing, spacing 400x400 mm, max weight of TV 20 kg

ATTENTION - SCHUCKO plugs only

Mediabox M04H

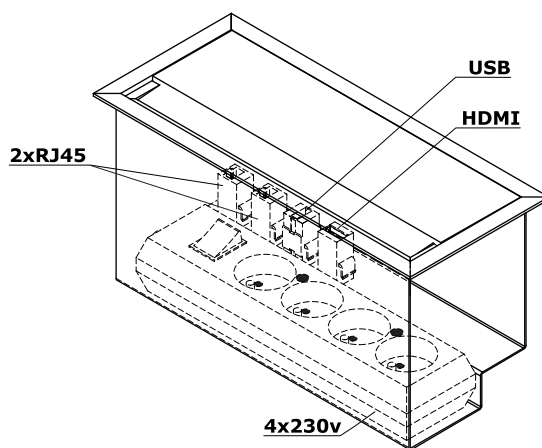

Cable management

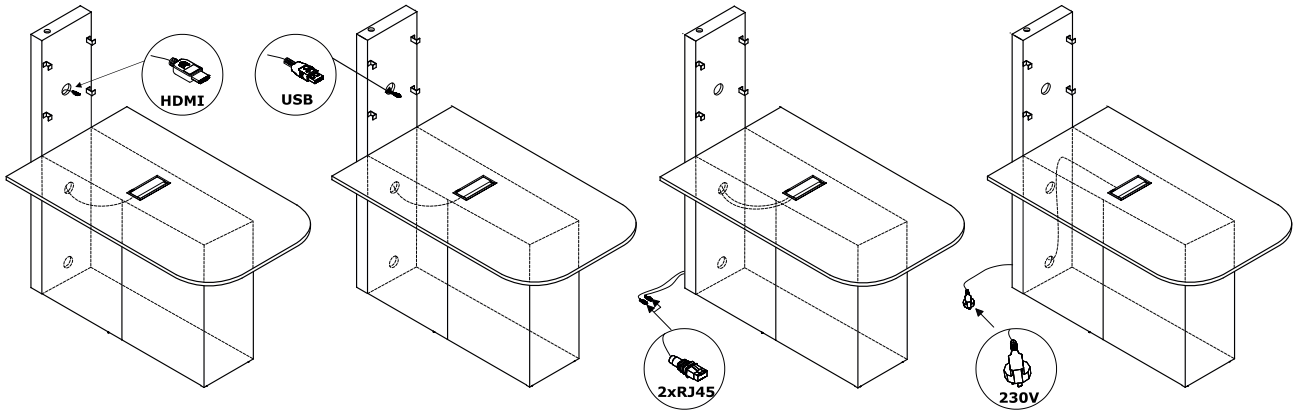

Dimensions MS01

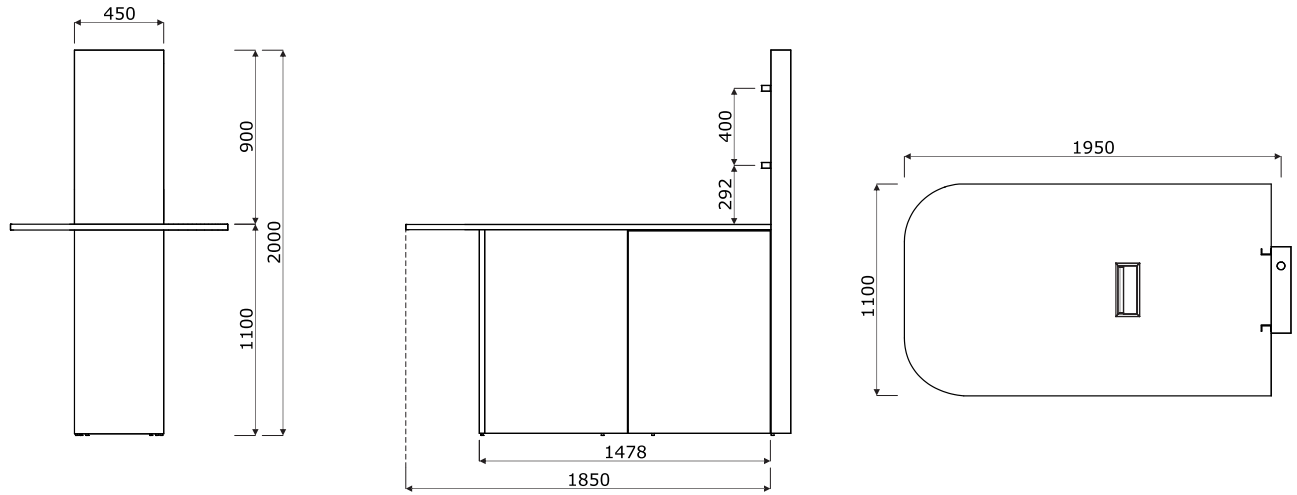

Dimensions MSW01

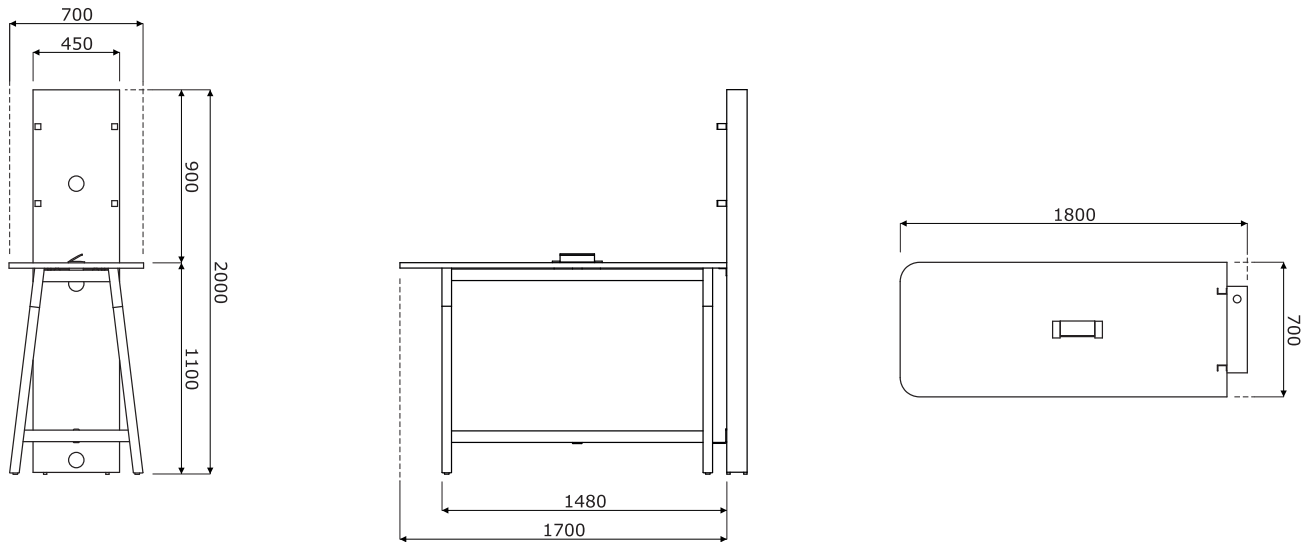

Multimedia stand MS01, MS02 *

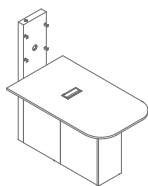

MS01
1100 / 1950 / 2000
121.3 kg

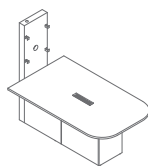

MS02
1100 / 1950 / 2000
99.6 kg

Multimedia stand MSW01 *



MSW01
700 / 1800 / 200
78.8 kg

* dimensions expressed in millimeters: width x depth x height

Multimedia stand	Date of preparation 10.02.2023	The data contained in this document is valid in the day of its preparation. Change of the product, as long as it does not affect the basic features of it, does not require consistent updates of the document.	page 6/7
			products

MS01, MS02



67 White pastel



08 Black



26 Aluminum satinato

MSW01

Top



26 Aluminum satinato



31 Canadian oak



39 Polar birch



64 Cocoa



168 Natural oak

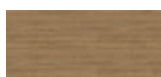

169 Honey oak

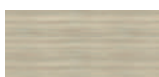

170 Acacia



67 White pastel



171 Dark walnut



167 Grey oak



154 Anthracite



08 Black

Frame - metal



M009 Aluminum semi-matt
RAL9006



M015 White semi-matt
RAL9010



M154 Antracite semi-matt
RAL7043



M115 Black semi-matt
RAL9005

Leg



Natural ash

Mediabox



M009 Aluminum semi-matt
RAL9006



M015 White semi-matt
RAL9010



M154 Antracite semi-matt
RAL7043



M115 Black semi-matt
RAL9005

ATTENTION - MSW01 - OPTION WITH EXTRA CHARGE - worktop edge, colour: ash natural