



muratto[®]
natural surface design

INDEX

ABOUT MURATTO	3
AWARDS	4
REFERENCES	5

COLLECTIONS	6
--------------------	---

ORGANIC BLOCKS COLLECTION

DESIGN BLOCKS

BEEHIVE	7
CHOCK	9
MINICHOCK	11
PEAK	13
SENSES	15
HEXAGON	17
DROP	19
STRIPS	21

COMPLEMENTS	23
--------------------	----

ACOUSTIC PANELS

UNDERTONE	25
BUZZER	27

CORK BRICKS COLLECTION

3D	29
GRAND	31
BEV	33

KORKSTONE COLLECTION

CLASSIC	35
TRIANGLE	37

METALEGANCE PURE COLLECTION	39
------------------------------------	----

PATTERN TILES COLLECTION

MOTIF	41
PATCHWORK	43

PRIMECORK COLLECTION	45
-----------------------------	----

NOTES	47
--------------	----

muratto[®]
natural surface design

WALL COVERING COLLECTIONS.

„MURATTO

is the brand name of distinguished natural surface design products. We create, promote, and distribute unique and outstanding natural collections, based upon the following basic principles: **DESIGN** as the focus of the creative process, **INNOVATION** in concept and technology, **VARIETY** in product offerings, and **WORLDWIDE** distribution. „

VASCO BARROS, MURATTO CEO

DESIGN It is the main driver in the product creation process, through co-creation with many international designers.

COMFORT Creating products that have differentiating characteristics, always offering the maximum comfort.

NATURE All creations and initiatives are based on the importance of sustainability, using natural products in the composition of all materials.

WORLDWIDE Distribution in more than 40 countries: Argentina, Australia, Austria, Belarus, Belgium, Brazil, Bulgaria, Canada, Costa Rica, Czech Republic, Croatia, Cyprus, Ecuador, Estonia, Finland, France, Germany, Greece, Hong Kong, Hungary, Iceland, India, Ireland, Israel, Italy, Japan, Jordan, South Korea, Kosovo, Latvia, Lithuania, Malaysia, Malta, Mexico, Middle East, Netherlands, New Zeland, Norway, Pakistan, Poland, Portugal, Romania, Russia, Singapore, South Africa, Spain, Switzerland, Taiwan, Turkey, UK, Ukraine, USA, Uzbekistan.

AWARDS

Over the past few years, Muratto has been influencing the world of interior design with its unique products around the world. Proof of this are the several awards that the brand has won over time worldwide.



NY Metro Chapter Award, USA, 2015



Design Tokyo Products Award, Japan, 2016



AIT Trendscouting Award, Euroshop, Germany, 2017



European Product Design Award, 2017



World Build Awards, WorldBuild Moscow / MosBuild, Russia, 2018



Best Exhibit Competition BD WEST LA, Boutique Design West, USA, 2018

REFERENCES

Muratto's presence all over the world is ever increasing, with design materials placed in the spaces of world-renowned brands. These are just some of the companies that created magically different spaces, in which Muratto has the pleasure of being present.

Google



Johnson & Johnson



amazon



NOBU HOTEL

BIRKENSTOCK

west elm

GERRIS.



TSYS®

iQOS



ORACLE



CASINO
FIGUEIRA

COLLECTIONS



ORGANIC BLOCKS



CORK BRICKS



KORKSTONE

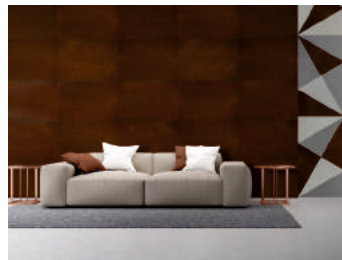

METALEGANCE PURE

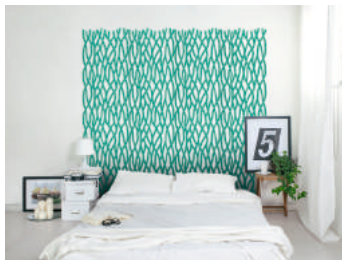

PATTERN TILES

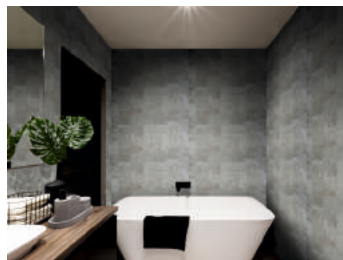

PRIMECORK

BEEHIVE DESIGN BLOCK - ORGANIC BLOCKS



BEEHIVE DESIGN BLOCK - ORGANIC BLOCKS

The shape of BEEHIVE results from the union of different geometrical planes that grow in an organic way. It is a progression from a basic honeycomb, at once natural and contemporary. The pattern appears to move, yet it is balanced, giving dynamism, energy and emotion to the environment.

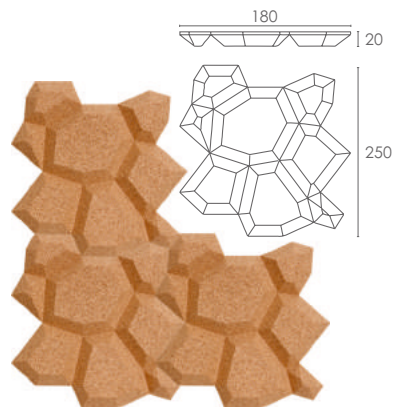

Ivory



Emerald



Yellow



Turquoise



Olive



Grey



Red



Bordeaux



Aubergine



Black



Natural



Taupe



Copper



Blue

MATERIAL Massive cork pieces agglomerated with special resins and additives, molded in shape with mass color pigmentation.

SIZE 250 x 180 x 20 mm

INSTALLATION glue or stickers

WEIGHT (BOX) 3,010 kg

PACKED 16 tiles, area 0,72 sqm

FIRE RESISTANT B-S1,d0 (En13823)

ACOUSTIC (NRC) 0,3 (EN ISO 11654)

THERMAL CONDUCTIBILITY (W/M.C) 0,0468 (EN 12667-2001)

THERMAL RESISTANCE (M2C/W) 0,47 (EN 12667-2001)

VOC class A (French Norm EN ISO/IEC 17025)

100% NATURAL
MADE MAINLY OF
CORK GRANULES,
NATURAL &
RECYCLABLE



CHOCK DESIGN BLOCK - ORGANIC BLOCKS



CHOCK DESIGN BLOCK - ORGANIC BLOCKS

Designed for high visual impact in larger areas and spacious rooms, CHOCK has four diagonal lines that emerge from the center of each square, like four windows that open in different directions. Thanks to the simple geometry of the four pieces that compose CHOCK, each piece retains its identity while blending into the overall effect.

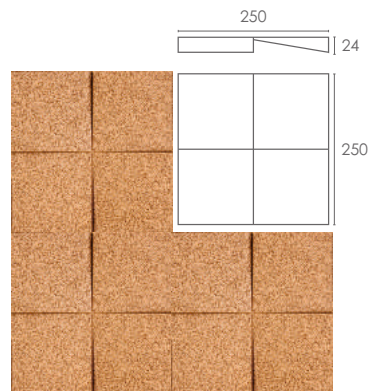

MATERIAL Massive cork pieces agglomerated with special resins and additives, molded in shape with mass color pigmentation.

SIZE 250 x 250 x 24 mm

INSTALLATION glue or stickers

WEIGHT (BOX) 3,330 kg

PACKED 16 files, area 1 sqm

FIRE RESISTANT B-S1,d0 (En13823)

ACOUSTIC (NRC) 0,3 (EN ISO 11654)

THERMAL CONDUCTIBILITY (W/M.C) 0,0468 (EN 12667-2001)

THERMAL RESISTANCE (M2C/W) 0,47 (EN 12667-2001)

VOC class A (French Norm EN ISO/IEC 17025)

100% NATURAL
MADE MAINLY OF
CORK GRANULES,
NATURAL &
RECYCLABLE



MINICHOCK DESIGN BLOCK - ORGANIC BLOCKS



MINICHOCK DESIGN BLOCK - ORGANIC BLOCKS

Designed for intimate spaces, MINICHOCK is composed of squares of four smaller squares meeting at different angles. The repeated shape creates a captivating mosaic pattern. The pattern is simple but contributes to an emotive, dynamic and playful environment.

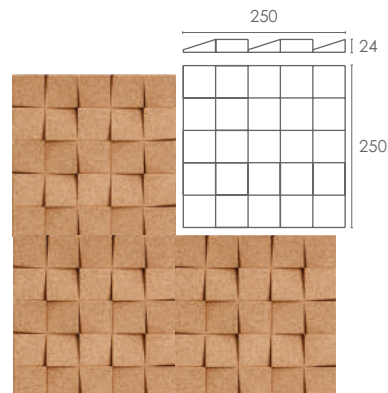

Ivory



Emerald



Yellow



Turquoise



Olive



Grey



Red



Bordeaux



Aubergine



Black



Natural



Taupe



Copper



Blue

MATERIAL Massive cork pieces agglomerated with special resins and additives, molded in shape with mass color pigmentation.

SIZE 250 x 250 x 24 mm

INSTALLATION glue or stickers

WEIGHT (BOX) 3,330 kg

PACKED 16 tiles, area 1 sqm

FIRE RESISTANT B-S1,d0 (En13823)

ACOUSTIC (NRC) 0,3 (EN ISO 11654)

THERMAL CONDUCTIBILITY (W/M.C) 0,0468 (EN 12667-2001)

THERMAL RESISTANCE (M2C/W) 0,47 (EN 12667-2001)

VOC class A (French Norm EN ISO/IEC 17025)

100% NATURAL
MADE MAINLY OF
CORK GRANULES,
NATURAL &
RECYCLABLE



PEAK DESIGN BLOCK - ORGANIC BLOCKS



PEAK DESIGN BLOCK - ORGANIC BLOCKS

Each square of the PEAK is made up of four asymmetrical triangles that converge at a peak. The repeated pattern suggests the idea of mountains and creates a reflection of the surrounding light. Turning to nature for inspiration, PEAK creates different moods based on the mixing and matching of colors.

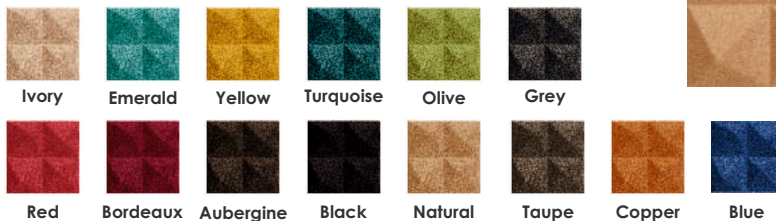
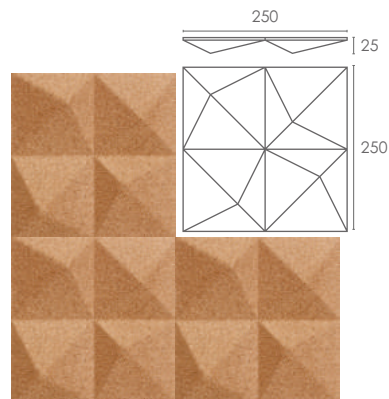

MATERIAL Massive cork pieces agglomerated with special resins and additives, molded in shape with mass color pigmentation.

SIZE 250 x 250 x 25 mm

INSTALLATION glue or stickers

WEIGHT (BOX) 3,045 kg

PACKED 16 tiles, area 1 sqm

FIRE RESISTANT B-S1,d0 (En13823)

ACOUSTIC (NRC) 0,3 (EN ISO 11654)

THERMAL CONDUCTIBILITY (W/M.C) 0,0468 (EN 12667-2001)

THERMAL RESISTANCE (M2C/W) 0,47 (EN 12667-2001)

VOC class A (French Norm EN ISO/IEC 17025)

100% NATURAL
MADE MAINLY OF
CORK GRANULES,
NATURAL &
RECYCLABLE



SENSES DESIGN BLOCK - ORGANIC BLOCKS



SENSES DESIGN BLOCK - ORGANIC BLOCKS

A smoothly curved hourglass shape is organized in horizontal and vertical orientations, creating an organic pattern. The shape of SENSES is inspired by the undulations the nature, and its volume gives dimension to smooth walls. SENSES can cover walls partially or entirely, allowing flexibility and individuality.

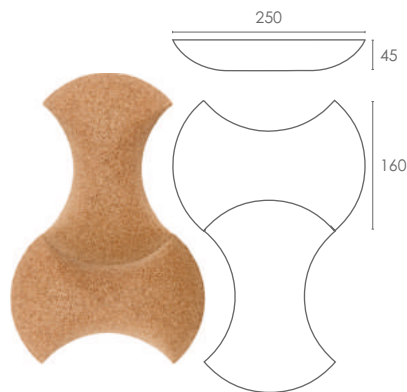

MATERIAL Massive cork pieces agglomerated with special resins and additives, molded in shape with mass color pigmentation.

SIZE 250 x 160 x 45 mm

INSTALLATION glue or stickers

WEIGHT (BOX) 2 kg

PACKED 15 tiles, area 0,435 sqm

FIRE RESISTANT B-S1,d0 (En13823)

ACOUSTIC (NRC) 0,3 (EN ISO 11654)

THERMAL CONDUCTIBILITY (W/M.C) 0,0468 (EN 12667-2001)

THERMAL RESISTANCE (M2C/W) 0,47 (EN 12667-2001)

VOC class A (French Norm EN ISO/IEC 17025)

100% NATURAL
MADE MAINLY OF
CORK GRANULES,
NATURAL &
RECYCLABLE



HEXAGON DESIGN BLOCK - ORGANIC BLOCKS



HEXAGON DESIGN BLOCK - ORGANIC BLOCKS

The HEXAGON is one of the geometric shapes that exists in nature, as does our cork material, and it is associated with communication, balance and union. By creating additional internal shapes, the HEXAGON allows a interface of each and all tiles, creating a unique result.

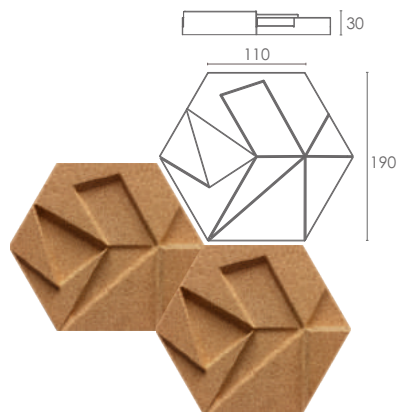

MATERIAL Massive cork pieces agglomerated with special resins and additives, molded in shape with mass color pigmentation.

SIZE 220 x 190 x 30 mm

INSTALLATION glue or stickers

WEIGHT (BOX) 3,220 kg

PACKED 22 tiles, area 0,688 sqm

FIRE RESISTANT B-S1,d0 (En13823)

ACOUSTIC (NRC) 0,3 (EN ISO 11654)

THERMAL CONDUCTIBILITY (W/M.C) 0,0468 (EN 12667-2001)

THERMAL RESISTANCE (M2C/W) 0,47 (EN 12667-2001)

VOC class A (French Norm EN ISO/IEC 17025)

100% NATURAL
MADE MAINLY OF
CORK GRANULES,
NATURAL &
RECYCLABLE



DROP DESIGN BLOCK - ORGANIC BLOCKS



DROP DESIGN BLOCK - ORGANIC BLOCKS

Having been inspired by motions of nature, DROP conveys the lightness and purity of water. This piece transforms a fluid dynamic combined with an organic surface, conveying a 3D feel due to its volume. The pattern created with this piece turns any wall into a realistic waterfall.

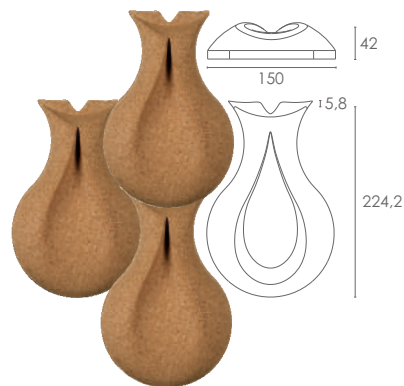

MATERIAL Massive cork pieces agglomerated with special resins and additives, molded in shape with mass color pigmentation.

SIZE 230 x 150 x 42 mm

INSTALLATION glue or stickers

WEIGHT (BOX) 2,600 kg

PACKED 15 tiles, area 0,337 sqm

FIRE RESISTANT B-S1,d0 (En13823)

ACOUSTIC (NRC) 0,3 (EN ISO 11654)

THERMAL CONDUCTIBILITY (W/M.C) 0,0468 (EN 12667-2001)

THERMAL RESISTANCE (M2C/W) 0,47 (EN 12667-2001)

VOC class A (French Norm EN ISO/IEC 17025)

100% NATURAL
MADE MAINLY OF
CORK GRANULES,
NATURAL &
RECYCLABLE



STRIPS DESIGN BLOCK - ORGANIC BLOCKS



STRIPS DESIGN BLOCK - ORGANIC BLOCKS

Composed by a series of horizontal stripes, the STRIPS are the perfect connection between simplicity and comfort. It is based on a high quality cork core with a selection of high density cork granules, and the final result is a continuous wall with a modern aspect. Its stripes and volume gives the piece a unique light effect.



MATERIAL Massive cork pieces agglomerated with special resins and additives, molded in shape with mass color pigmentation.

SIZE 690 x 390 x 7 mm

INSTALLATION glue

WEIGHT (BOX) 6,200 kg

PACKED 10 tiles, area 2,691 sqm

FIRE RESISTANT B-S1,d0 (En13823)

ACOUSTIC (NRC) 0,3 (EN ISO 11654)

THERMAL CONDUCTIBILITY (W/M.C) 0,0468 (EN 12667-2001)

THERMAL RESISTANCE (M2C/W) 0,47 (EN 12667-2001)

VOC class A (French Norm EN ISO/IEC 17025)

100% NATURAL
MADE MAINLY OF
CORK GRANULES,
NATURAL &
RECYCLABLE



COMPLEMENTS DESIGN BLOCKS - ORGANIC BLOCKS

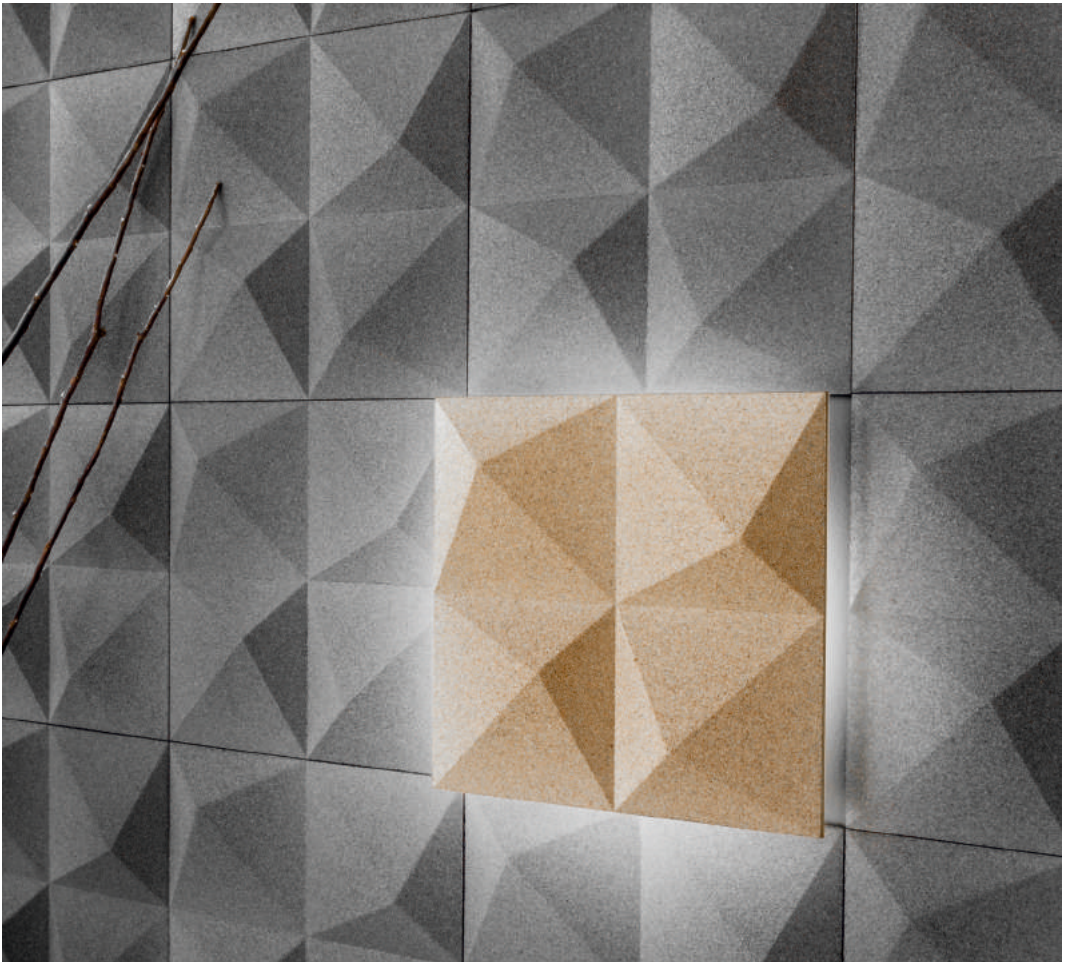

COMPLEMENTS DESIGN BLOCKS - ORGANIC BLOCKS

LIGHTING MODULES

The LIGHTING MODULES provide a complete new level of decoration and design, creating different patterns with the same product. Developed for CHOCK, MINICHOCK and PEAK. Designed and assembled in Germany.

INSTALLATION GUIDE The LED Lamp is pre-wired and pre-assembled for wall mounting installation. The module must be placed centered on the wall surface. The distance between the drill holes is 7,7cm. The installation should be done by an experienced technician. LED driver from MW-Lighting has CE.

SIZE 200 x 200 x 40 mm

COLOR black and white

INSTALLATION screws (fix to the wall) /
glue (for the design block)

LAMP 8 LED/

POWER 10 W

WEIGHT (BOX) 0,890 kg

TENSION 230 V

PACKED 1 module

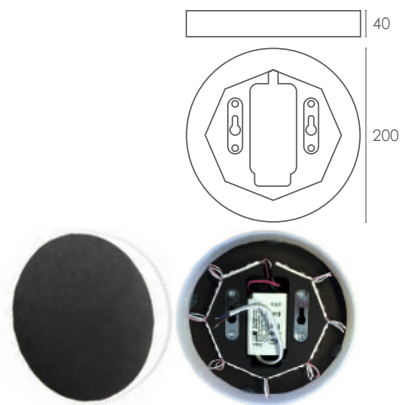

STICKERS

STICKERS are a complement to fix the DESIGN BLOCKS without applying adhesive. Composed of scrim tape with an acrylic glue, they are easy to use, completely transparent, very strong yet still removable.

SIZE 20 mm (diameter)

COLOR transparent

PACKED sheets of 16 stickers

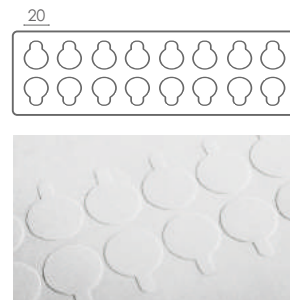

UNDERTONE ACOUSTIC PANEL - ORGANIC BLOCKS



UNDERTONE ACOUSTIC PANEL - ORGANIC BLOCKS

Besides having a high aesthetic impact, the UNDERTONE was specifically developed as an acoustic panel. Its design was technically prepared to dissipate sound waves, through the rounded shapes and numerous holes. Although UNDERTONE'S main aim is to insulate sound, its design is contemporary and appealing, and displays beautiful light and shadow effects.

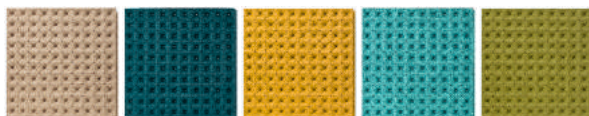
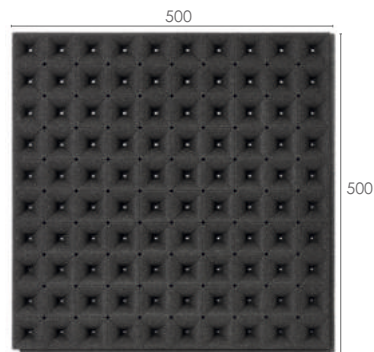

Ivory

Emerald

Yellow

Turquoise

Olive

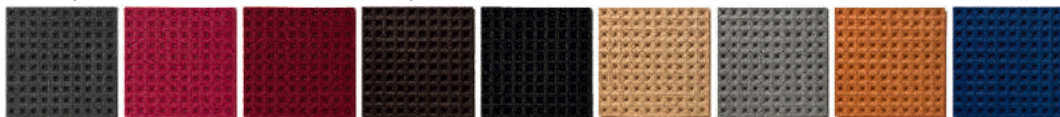

Grey

Red

Bordeaux

Aubergine

Black

Natural

Taupe

Copper

Blue

MATERIAL Massive cork pieces agglomerated with special resins and additives, molded in shape with mass color pigmentation.

SIZE 500 x 500 x 30 mm

INSTALLATION glue / clips (ask for more information)

WEIGHT (BOX) 5,900 kg

PACKED 4 tiles, area 1 sqm

FIRE RESISTANT B-S1,d0 (En13823)

ACOUSTIC (NRC) (Please check complete acoustic report on our webpage)

THERMAL CONDUCTIBILITY (W/M.C) 0,0468 (EN 12667-2001)

THERMAL RESISTANCE (M2C/W) 0,47 (EN 12667-2001)

VOC class A (French Norm EN ISO/IEC 17025)

100% NATURAL
MADE MAINLY OF
CORK GRANULES,
NATURAL &
RECYCLABLE



BUZZER ACOUSTIC PANEL - ORGANIC BLOCKS



BUZZER ACOUSTIC PANEL - ORGANIC BLOCKS

Besides of having a high aesthetich impact, the BUZZER was specifically developed as an acoustic panel. Its design was technically prepared to dissipate sound waves, through the squared shapes in pyramid form. Although BUZZER'S main purpose is to insulate sound, its design is contemporary and appealing, displaying beautiful light and shadow effects.

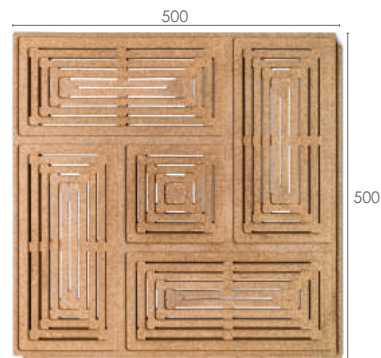

Ivory Emerald Yellow Turquoise Olive



Grey Red Bordeaux Aubergine Black Natural Taupe Copper Blue

MATERIAL Massive cork pieces agglomerated with special resins and additives, molded in shape with mass color pigmentation.

SIZE 500 x 500 x 30 mm

INSTALLATION glue / clips (ask for more information)

WEIGHT (BOX) 8,500 kg

PACKED 4 tiles, area 1 sqm

FIRE RESISTANT B-S1,d0 (En13823)

ACOUSTIC (NRC) (Please check complete acoustic report on our webpage)

THERMAL CONDUCTIBILITY (W/M.C) 0,0468 (EN 12667-2001)

THERMAL RESISTANCE (M2C/W) 0,47 (EN 12667-2001)

VOC class A (French Norm EN ISO/IEC 17025)

100% NATURAL
MADE MAINLY OF
CORK GRANULES,
NATURAL &
RECYCLABLE



CORK BRICKS 3D



CORK BRICKS 3D

CORK BRICKS 3D is made of light cork pieces, with a natural treatment. It comes in different thicknesses, and is painted with an innovative immersion process. The high value raw material and the handmade process creates a unique aesthetic natural result. These distinguishing characteristics make CORK BRICKS 3D one of the most noted products of all ranges.

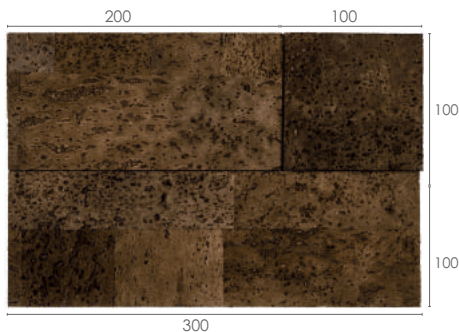

MATERIAL Massive cork pieces agglomerated with special resins and additives, molded in shape with mass color pigmentation.

SIZE 300 x 100 x 7 + 200 x 100 x 11 + 100 x 100 x 14 mm

INSTALLATION glue

WEIGHT (BOX) 2,70 kg

PACKED 27 tiles (9 of each size), area 0,54 sqm

ACOUSTIC (NRC) 0,15 (EN ISO 11654)

THERMAL CONDUCTIBILITY (W/M.C) 0,0468 (EN 12667-2001)

THERMAL RESISTANCE (M2C/W) 0,47 (EN 12667-2001)



CORK BRICKS GRAND



CORK BRICKS GRAND

CORK BRICKS GRAND is an allusion to the traditional brick, while renewing the vision of cork in its natural form, yet continuing the sense of comfort and warmth. The CORK BRICKS GRAND provide an immensity of pattern possibilities, through the endless array of shape and color combinations. The style of European artisanship and the handmade contemporary appeal provide an irreverent appearance to the CORK BRICKS GRAND, while the inherent aspects of cork still remain true.

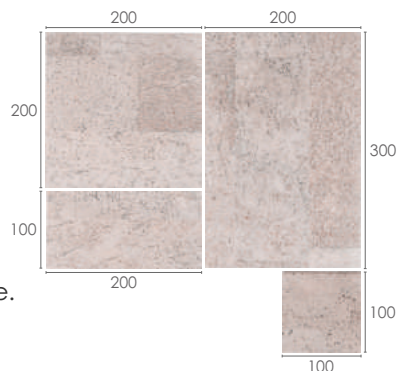

MATERIAL Massive cork pieces agglomerated with special resins and additives, molded in shape with mass color pigmentation.

SIZE 300 x 200 x 4 + 200 x 200 x 7 + 200 x 100 x 11 + 100 x 100 x 14 mm

INSTALLATION glue

WEIGHT (BOX) 3 kg

PACKED 32 tiles (8 of each size), area 1,04 sqm

ACOUSTIC (NRC) 0,15 (EN ISO 11654)

THERMAL CONDUCTIBILITY (W/M.C) 0,0468 (EN 12667-2001)

THERMAL RESISTANCE (M2C/W) 0,47 (EN 12667-2001)





CORK BRICKS BEV

With a rustic and modern look at the same time, the BEV has a rough but distinct aspect because of its similarity to the natural cork bricks. It stands out because of their bevelled edges, which gives it a bigger volume effect. CORK BRICKS BEV provides a natural but luxurious look to any room.

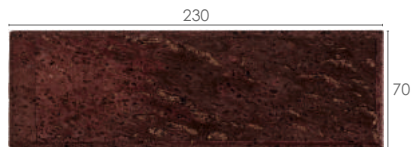

MATERIAL Natural cork pieces, four bevelled sides, pre-cleaned and treated, with an immersion finish of color pigments and other protection additives.

SIZE 230 x 70 x 7 mm

INSTALLATION glue

WEIGHT (BOX) 3,40 kg

PACKED 62 tiles, area 0,99 sqm

ACOUSTIC (NRC) 0,15 (EN ISO 11654)

THERMAL CONDUCTIBILITY (W/M.C) 0,0468 (EN 12667-2001)

THERMAL RESISTANCE (M2C/W) 0,47 (EN 12667-2001)



KORKSTONE CLASSIC



KORKSTONE CLASSIC

KORKSTONE CLASSIC has both sparkling and velvety aspects, with a light-weight, yet strong, product composition. Based upon handmade qualities, realised through technology upgrades, KORKSTONE CLASSIC enlance both irreverent and luxury aesthetics.

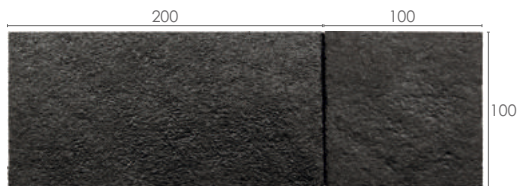

MATERIAL Massive cork tiles, high density weight molded in irregular surface, with metallic color pigments.

SIZE 200 x 100 + 100 x 100 mm

INSTALLATION glue

WEIGHT (BOX) 5,10 kg

PACKED 66 tiles (33 of each size), area 0,99 sqm

FIRE RESISTANT B (USA Norm ASTM E84)



KORKSTONE TRIANGLE



KORKSTONE TRIANGLE

KORKSTONE TRIANGLE is inspired by geometric shapes that form unique and outstanding pattern combinations. KORKSTONE TRIANGLE has both sparkling and velvety aspects, with a light-weight, yet strong, product composition. Based upon handmade qualities, realised through technology upgrades, KORKSTONE TRIANGLE enlance both irreverent and luxury aesthetics. KORKSTONE TRIANGLE praises the design trend that uses this geometric shape, which is also ideal for application to larger areas.

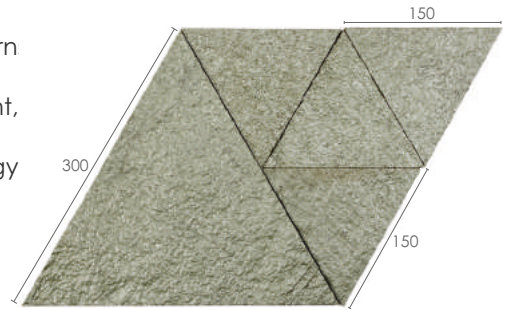

MATERIAL Massive cork tiles, high density weight molded in irregular surface, with metallic color pigments.

SIZE 150 x 150 x 150 + 300 x 300 x 300 mm

INSTALLATION glue

WEIGHT (BOX) 3 kg

PACKED 51 tiles (34 of 150 mm + 17 of 300 mm), area 1 sqm

FIRE RESISTANT B (USA Norm ASTM E84)



METALEGANCE PURE



METALEGANCE PURE

Made with natural metallic granules, a silicate compound and oxide aluminum, the METALEGANCE PURE is the most recent and refreshing material in the world of wall coverings. Besides being produced with the latest high-tech, it is defined by its metallic appearance and magnetic feature, combined with an elegant and striking look. Its extraordinary surface is endowed with high dimensional stability and flexibility. Fire and water resistant.



White Cement



Clear Cement

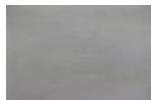

Platin Cement

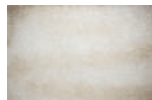

Brass

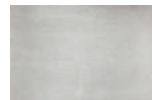

Platinum



Black



Royal Gold



Old Gold



Copper



Old Bronze



Oxid

MATERIAL Panels with a core composition mixture of natural components (modified silicates, oxide aluminum, mineral technical charges) finished with a layer of metallic granules with natural pigments and synthetic blends.

SIZE 900 x 600 x 2 mm

INSTALLATION glue

WEIGHT (BOX) 12 kg

PACKED 8 pieces

FIRE RESISTANT A2/B (EN 1384)



MOTIF PATTERN TILES



MOTIF PATTERN TILES

Patterns range from classic to modern. Easy home redecoration, to achieve an excellent aesthetic result. The thick patterns create a 3D effect, as well as contrast, due to the wall color that is exposed through the pattern. Completed with a self-adhesive backing, for easy application.



ARABIC

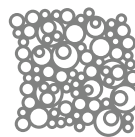

BUBBLES



CINETIC



CITIES



CLASSIC



CORAL



NOTOUCH



PERSPECTIVE

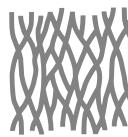

ROOTS

MATERIAL Agglomerated cork, cut in the selected design by precision industrial machines, finished with color pigmentation and wax protection. Completed with a self-adhesive backing.

SIZE approximately 500 x 500 x 3,5 mm (item dependant)

INSTALLATION self-adhesive

WEIGHT (BOX) 1,10 kg

PACKED 4 tiles, area 1 sqm (approx.)

POSSIBLE TO DO ANY SHAPE IN ANY COLOR please ask for more informations

NATURAL
MADE MAINLY OF
CORK GRANULES,
100% NATURAL &
RECYCLABLE



PATCHWORK PATTERN TILES



PATCHWORK PATTERN TILES

Patterns range from classic to modern. Easy home redecoration, to achieve an excellent aesthetic result. The thick patterns create a 3D effect, as well as contrast, due to the wall color that is exposed through the pattern. Completed with a self-adhesive backing, for easy application.

REVIVAL PATCHWORK

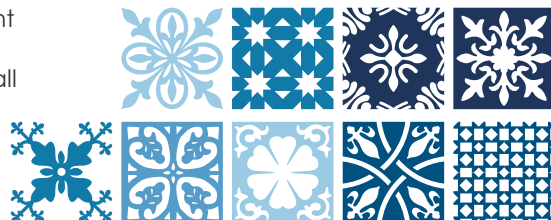

MEDITERRANEAN PATCHWORK



MATERIAL Agglomerated cork, cut in the selected design by precision industrial machines, finished with color pigmentation and wax protection. Completed with a self-adhesive backing.

SIZE approximately 200 x 200 x 3,5 mm (item dependant)

INSTALLATION self-adhesive

WEIGHT (BOX) 1,15 kg

PACKED 27 tiles (3 x 9 different tiles), area 1,08 sqm (approx.)

POSSIBLE TO DO ANY SHAPE IN ANY COLOR please ask for more informations

NATURAL
MADE MAINLY OF
CORK GRANULES,
100% NATURAL &
RECYCLABLE





PRIMECORK

This rich natural cork skin provides a «Classic Look» to the interior walls of any space. Its warm and comfortable look makes it compatible with every decorating style, from the modern to the very traditional. This natural «skin» of silty touch, smooth and unobtrusive aesthetics, makes beautiful walls in a timeless way.



Ivory



Natural



Cappuccino



Moka



Brown



Leather



Champagne



Taupe



Silver



Marble

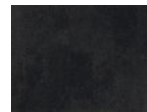

Dark grey



Black

MATERIAL Panels with two layers. Massive cork tiles with color pigments, and a natural finishing treatment on the top. Water repellent.

SIZE 600 x 450 x 4 mm

INSTALLATION glue

WEIGHT (BOX) 6,20 kg

PACKED 12 tiles, area 3,24 sqm



NOTES

www.muratto.com





muratto[®]

Showroom: Rua Pedro Homem de Melo, nº 242-A, Porto - Portugal

marketing@muratto.com | www.muratto.com

facebook.com/muratto.wall | instagram.com/muratto.wall